

## KLT-L55B-IMX351 V1.0

### 16MP Sony IMX351 MIPI Interface Auto Focus Camera Module

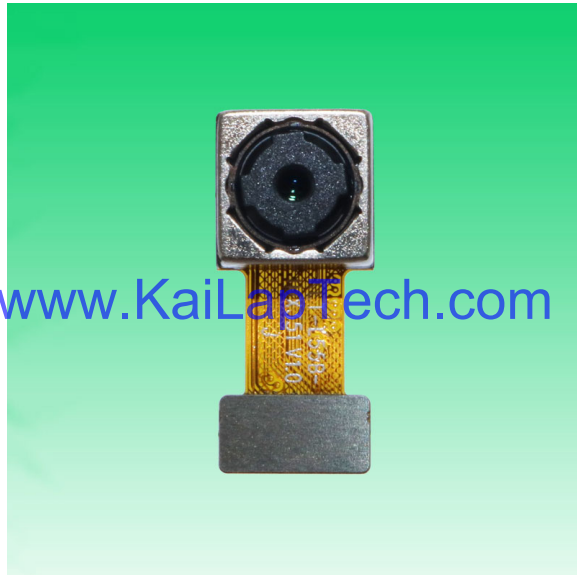

Front View

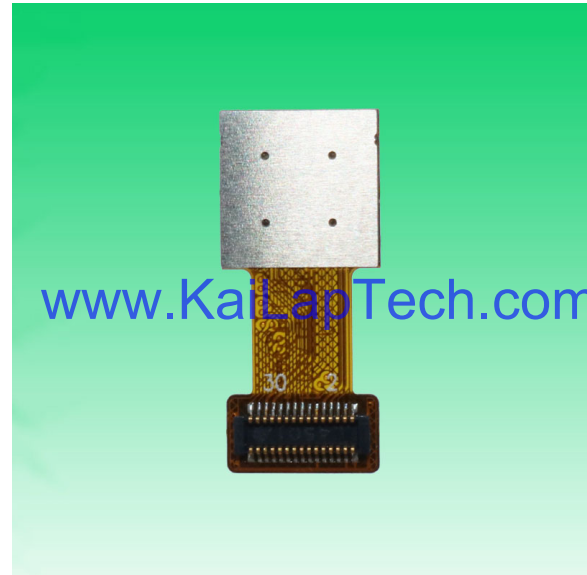

Back View

#### Specifications

Camera Module No.	KLT-L55B-IMX351 V1.0
Resolution	16MP
Image Sensor	IMX351
Sensor Type	1/3.09"
Pixel Size	1.0 um x 1.0 um
EFL	3.85 mm
F.NO	2.20
Pixel	4688 x 3648
View Angle	74.4°(DFOV) 62.7°(HFOV) 48.7°(VFOV)
Lens Dimensions	8.50 x 8.50 x 5.60 mm
Module Size	20.00 x 8.50 mm
Module Type	Auto Focus
Interface	MIPI
Auto Focus VCM Driver IC	CN3927
Lens Model	KLT-LENS-PS50013A1
Lens Type	650nm IR Cut
Operating Temperature	-20°C to +70°C
Mating Connector	GB042-30S-H10



## KLT-L55B-IMX351 V1.0

### 16MP Sony IMX351 MIPI Interface Auto Focus Camera Module



Top View



Side View

[www.KaiLapTech.com](http://www.KaiLapTech.com)

[www.KaiLapTech.com](http://www.KaiLapTech.com)

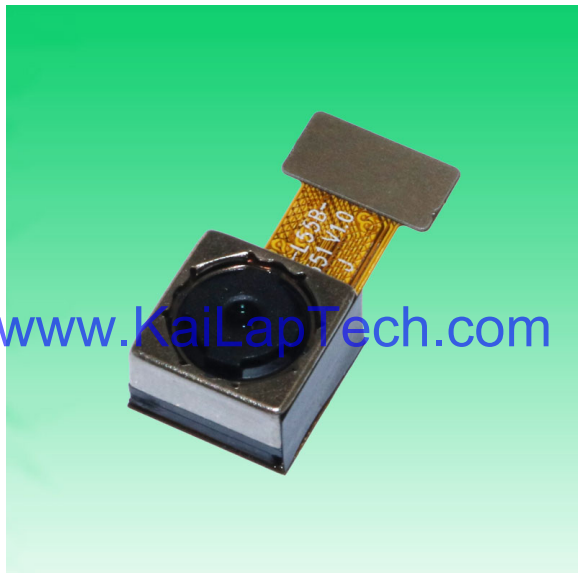

Bottom View



Mating Connector

# RoHS

1	DGND
2	DGND
3	DGND
4	XSHUTDOWN(RST)
5	VDD_VCM 2.8V
6	PWDN_VCM
7	SDA
8	DOVDD 1.8V
9	SCL
10	DVDD 1.05V
11	DGND
12	NC
13	CLK_N
14	NC
15	CLK_P
16	DGND
17	DATA0_N
18	MCLK
19	DATA0_P
20	DGND
21	DATA1_N
22	NC
23	DATA1_P
24	AVDD 2.8V
25	NC
26	AGND
27	DATA2_N
28	DATA3_N
29	DATA2_P
30	DATA3_P

1  
ø6.00(Lens Dia)

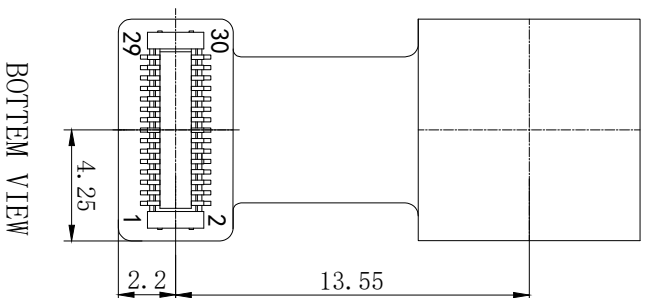
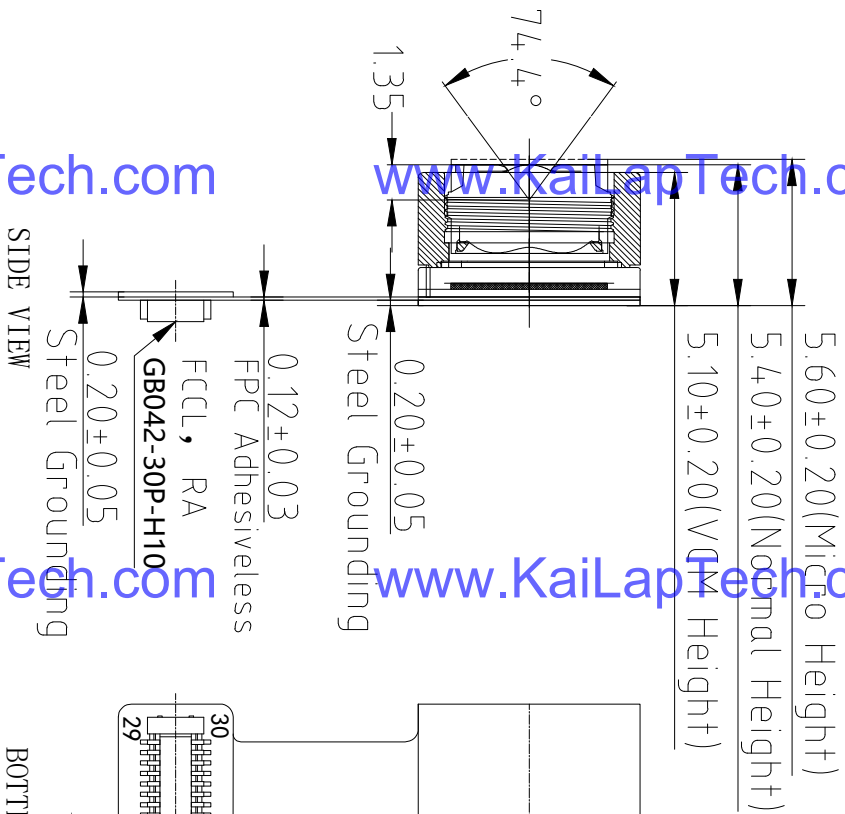
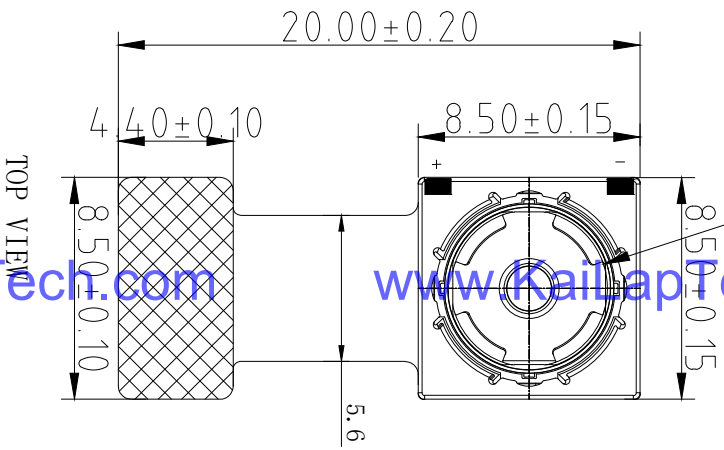

NOTE:  
1.The device slave address:0x34(w);0x35(r)

## Parameters:

### 1、Sensor specification:

Image Sensor: IMX351  
Pixel: 1.0um×1.0um  
Lens Type: 1/3.09  
Important Voltage Description: DVDD1.05V (external power supply);

### 2 Lens specification:

FOV: 74.4°(D);62.7°(H);48.7°(V)  
F/#: 2.2  
TV distortion: <1.5%  
Focal length: 3.85mm  
Composition: 5P+IR FILTER  
IR Cut Coating: 650nm±10nm@50%

Kai Lap Technologies Group Ltd

Designed By

Keyid

Model Name:

KLT-L55B-IMX351 V1.0

Checked By

Aouly Yan

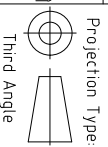

Unit: mm  
Scale: 1:1

Material: -----  
Sheet: 1 of 1  
Version: 1/0

Version	Information	Date
V1.0	First Version	6-30-2022



Lens Model: KLT-LENS-PS50013A1

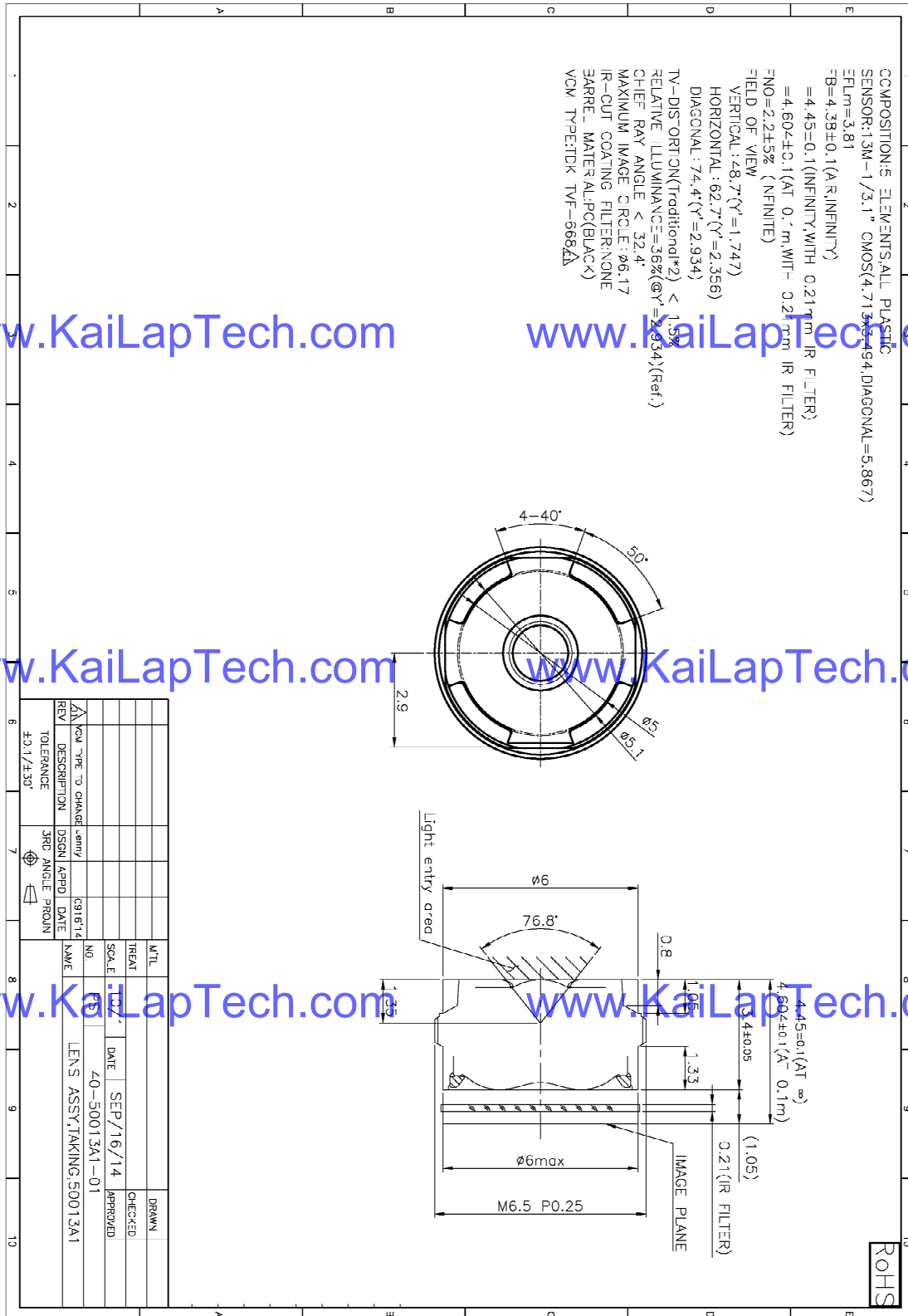

www.KaiLapTech.com

www.KaiLapTech.com

www.KaiLapTech.com

www.KaiLapTech.com

www.KaiLapTech.com

www.KaiLapTech.com

# CN3927

## Low Voltage Voice Coil Motor Driver with I2C interface

### 1. Description

The CN3927 is single 10-bit DAC with 150mA output current sink capability. Designed for linear control of voice coil motors, the CN3927 is capable of operating voltage from 2.3V to 5.5V. The DAC is controlled via a I2C serial interface that operates DAC by clock rates up to 400kHz.

The CN3927 incorporates with a UVLO reset circuit, power-down function, and exactly matched sense resistor. UVLO reset circuit ensure when supply power up, DAC output is to 0V until valid write-bit value takes place. It has a power down features that reduces the current consumption of the device to 1uA maximum.

The CN3927 is designed for auto focus and optical zoom camera phones, digital still cameras, and camcorders applications. The I2C address for the CN3927 is 0x18.

### Features

- WLCSP package for minimum footprint
- Ramp control circuit
- Fixed I<sup>2</sup>C logic thresholds
- 10-bit D-to-A converter
- 146μA *I<sub>out</sub>* resolution
- I2C serial interface (1.8V input available)
- Low current sleep mode
- 2.3 to 5.5 V power supply

### Applications

- Digital camera
- Cell phone
- Lens auto focus
- Web camera

### Package:

- 6-Bump Chip Scale Package
- 0.80mm (W) x 1.20mm (H) x 0.3mm (T)
- 0.4mm Bump Pitch



### 2. Functional Block Diagram

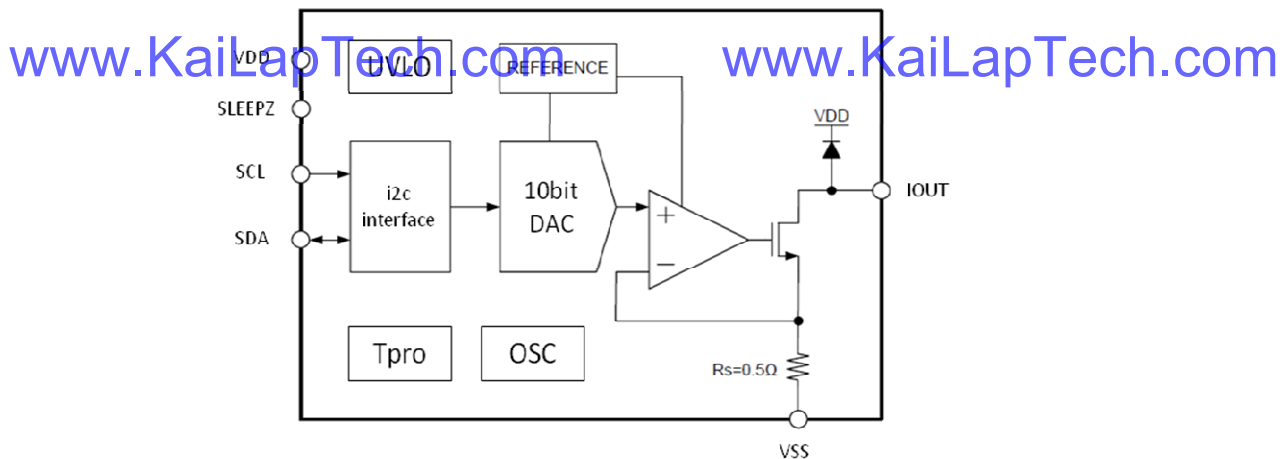

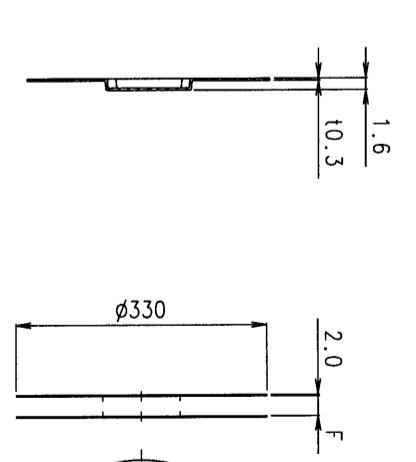
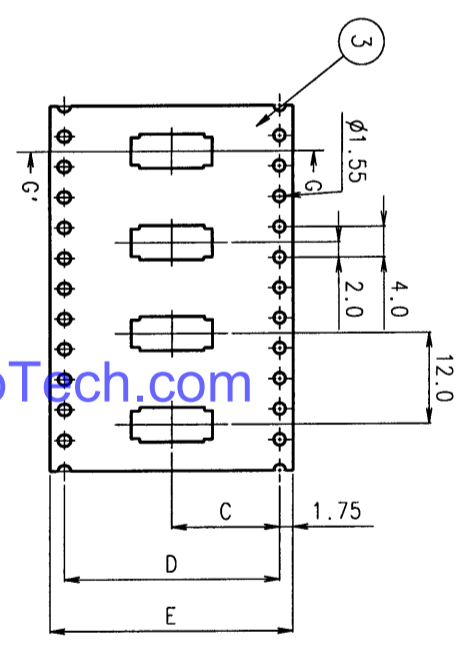
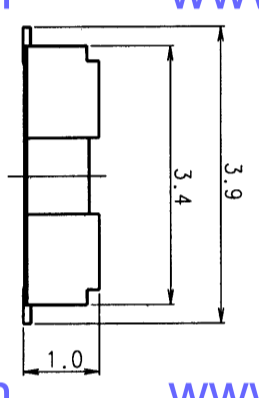
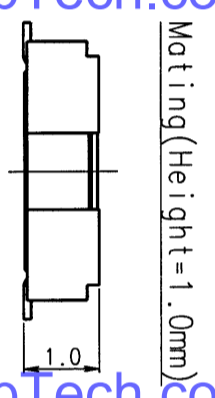
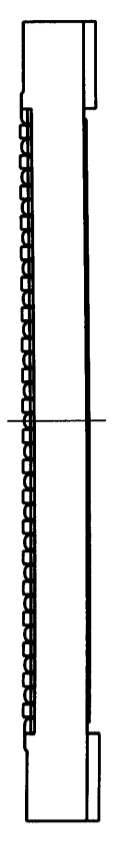
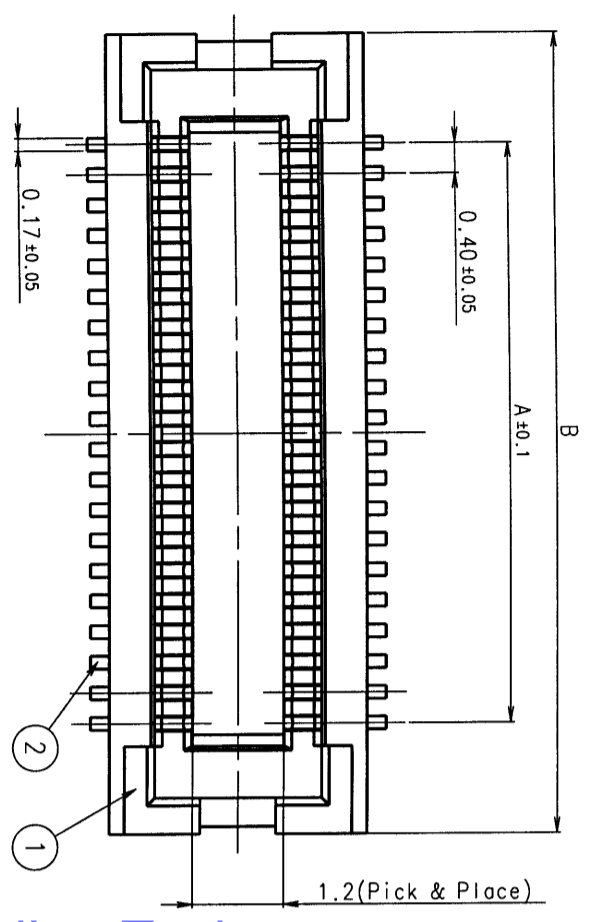

Recommended PCB Lay-Out

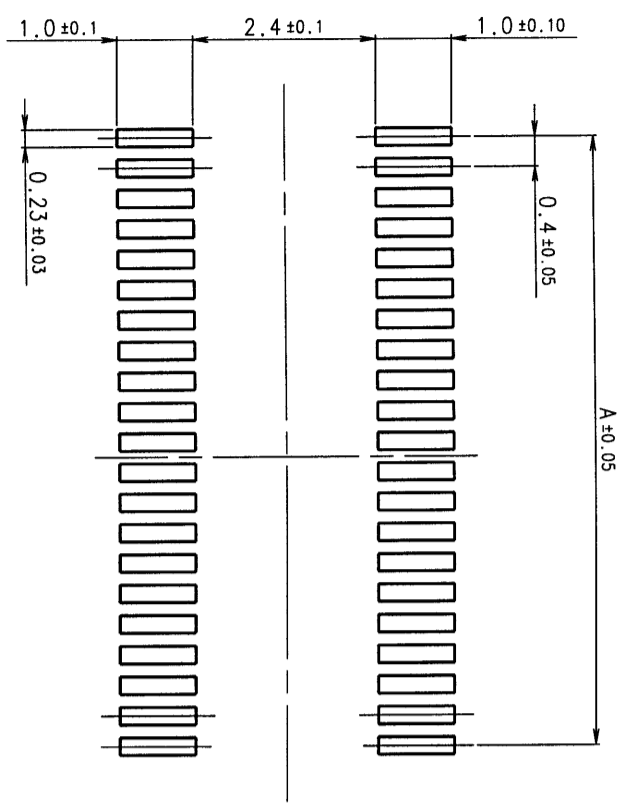
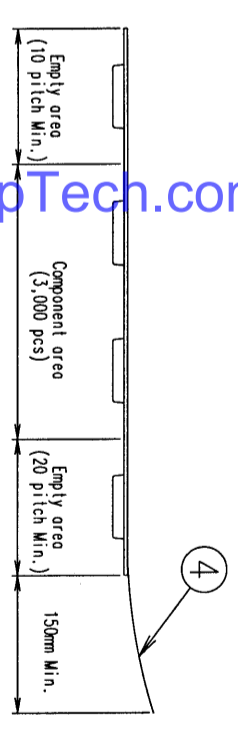

Table 1

No. of Positions	A	B	C	D	E	F
20	3.6	6.5	7.5	—	16.0	18.0
24	4.4	7.3	—	—	16.0	18.0
30	5.6	8.5	—	—	—	—
34	6.4	9.3	—	—	—	—
40	7.6	10.5	11.5	—	24.0	26.0
50	9.6	12.5	—	—	—	—
54	10.4	13.3	—	—	—	—
60	11.6	14.5	—	—	—	—
70	13.6	16.5	14.2	28.4	32.0	34.0
80	15.6	18.5	—	—	—	—

ITEM	DESCRIPTION	Q'TY	MATERIAL	FINISH	REMARKS
1	Recep. Insulator	1	Engineering Plastic	-	UL94V-0
2	Recep. Contact	n	Copper Alloy	Au over Ni	-
3	Carrier Tape	1	Polyester or Polystyrene	-	-
4	Cover Tape	1	Polyester or Polystyrene	-	-
5	Bobbin	1	Plastic	-	-



4. Co-planarity of contacts is 0.1mm Max.

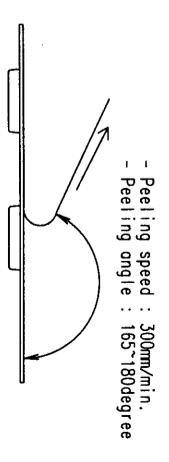

[NOTE] 1. Ordering Information

GB042 - \*\* S - H10 - E3000  
 No of [ ] Receptacle  
 position [ ] 3,000pcs/Plastic reel

2. Packing Specification

3. Peel strength : 10~70g

UNIT - mm  
 GENERAL TOLERANCES:  
 DIMENSION . X ± 0.2  
 . XX ± 0.1  
 ANGLES X . X

REFERENCE DOCUMENT: LGC(25)-K-AS118  
 DATE: Mar. 31. 2005  
 MATERIAL: K.C. Park  
 TREATMENT: CHECKED  
 FINISH: APPROVED D.H. Kim

SERIES: GB042  
 SHEET: 1 / 1  
 TITLE: GB042 Receptacle (GB042-\*\*S-H10)  
 SCALE: 10/1  
 SIZE: A3

DWG. NO: GUS511802

555, Hoeye-Dong, Anyang-Si, Kyungki-Do, 430-080, KOREA

REV. NO	DATE	DCN. NO	REMARKS	DES. D	CHE. D	APP. D

# GB042 series 0.4mm pitch PCB to PCB Connector



### Features

- GB042 series Connector is 0.4 mm pitch, low profile PCB to PCB SMT type connector.
- Improved contact reliability with plug and receptacle contacting at 2 point simultaneously.
- Stable unmating mechanism preventing receptacle contact from being deformed.

### Applications

- Mobile phone
- Compact portable devices, etc

### Materials & Finishes

Parts	Materials / Finishes
Insulator	UL94V-0
Plug	Copper Alloy
Recept.	Copper Alloy Au Plating

### Specifications

No. of Contacts	10-80
Stacking Height	1.0mm
Contact Spacing	0.4mm
Current Rating	AC, DC 0.3A/pin
Voltage Rating	AC, DC 50V
Dielectric Withstanding Voltage	AC 250V (rms for one minute)
Insulation Resistance	1000MΩ
Contact Resistance	70mΩ
Operating Temp.	-25°C ~ +85°C

### Ordering Information

Series	GB042	No. of Contacts	40	Contact Type	P	Mating Height	H10
--------	-------	-----------------	----	--------------	---	---------------	-----

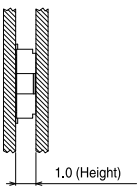

www.KaiLapTech.com

www.KaiLapTech.com

www.KaiLapTech.com

www.KaiLapTech.com

### Receptacle



### Embossed Tape Assembly

#### Bobbin

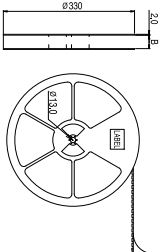

www.KaiLapTech.com

www.KaiLapTech.com

### GB042 series | Receptacle & Embossed Tape Assembly

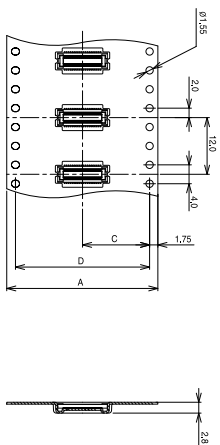
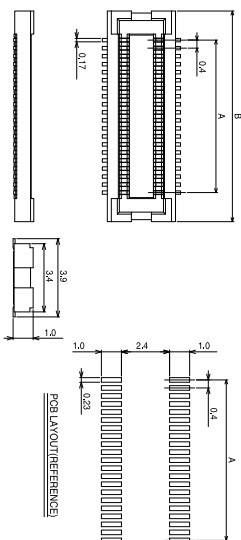

No. of Pin	Part Number	Receptable		Embossed Tape Assembly			
		A	B	A	B	C	D
10	GB042-10S-**-H10-E3000	1.6	4.5				
20	GB042-20S-**-H10-E3000	3.6	6.5	16.0			
24	GB042-24S-**-H10-E3000	4.4	7.3		18.0	7.5	
28	GB042-28S-**-H10-E3000	5.2	8.1				
30	GB042-30S-**-H10-E3000	5.6	8.5				
34	GB042-34S-**-H10-E3000	6.4	9.3				
40	GB042-40S-**-H10-E3000	7.6	10.5				
44	GB042-44S-**-H10-E3000	8.4	11.3	24.0	26.0	11.5	-
50	GB042-50S-**-H10-E3000	9.6	12.5				
54	GB042-54S-**-H10-E3000	10.4	13.3				
60	GB042-60S-**-H10-E3000	11.6	14.5				
64	GB042-64S-**-H10-E3000	12.4	15.3	32.0			
70	GB042-70S-**-H10-E3000	13.6	16.5		34.0	14.2	28.4

www.KaiLapTech.com

www.KaiLapTech.com

Diagonal 5.822 mm (Type 1/3.09) 16Mega-Pixel CMOS Image Sensor with Square Pixel for Color Cameras

## IMX351-AAQH5-C

---

### General description and application

IMX351 is a diagonal 5.822 mm (Type 1/3.09) 16 Mega-pixel CMOS active pixel type stacked image sensor with a square pixel array. It adopts Exmor RS™ technology to achieve high speed image capturing by column parallel A/D converter circuits and high sensitivity and low noise image (comparing with conventional CMOS image sensor) through the backside illuminated imaging pixel structure. R, G, and B pigment primary color mosaic filter is employed. By introducing spatially multiplexed exposure technology, high dynamic range still pictures and movies are achievable. It equips an electronic shutter with variable integration time. It operates with four power supply, analog 2.8 V, 1.8V, digital 1.05 V and 1.8 V for input/output interface and achieves low power consumption. In addition, this product is designed for use in cellular phone and tablet pc. When using this for another application, Sony does not guarantee the quality and reliability of product. Therefore, don't use this for applications other than cellular phone and tablet pc. Consult your Sony sales representative if you have any questions.

---

### Functions and Features

- ◆ Back-illuminated and stacked CMOS image sensor Exmor RS
- ◆ High Frame Rate 30fps@Full resolution / 60fps@4K2K / 240fps@1080p / 240fps@720p
- ◆ Spatially Multiplexed Exposure High Dynamic Range (SME-HDR) with equivalent full pixels (Raw data output)
- ◆ Phase Detection Auto Focus (PDAF)
- ◆ Electronic Image Stabilization (EIS)
- ◆ Diffraction Limit Compensation (DLC)
- ◆ High signal to noise ratio(SNR)
- ◆ Dual sensor synchronization operation
- ◆ Built-in 2D Dynamic Defect Pixel Correction
- ◆ Lens Shading Correction (LSC)
- ◆ Built-in temperature sensor
- ◆ Output video format of RAW10/8, COMP8
- ◆ Pixel binning readout function
- ◆ Two PLLs for independent clock generation for pixel control and data output interface
- ◆ CSI-2 serial data output (MIPI 2lane/4lane, Max. 2.3Gbps/lane, D-PHY spec. ver. 1.2 compliant)
- ◆ 2-wire serial communication
- ◆ Advanced Noise Reduction (Color noise reduction and RAW noise reduction)
- ◆ Low Noise Capture Mode
- ◆ 10K bit of OTP ROM for users

## Exmor RS

Sony reserves the right to change products and specifications without prior notice.

This information does not convey any license by any implication or otherwise under any patents or other right.

Application circuits shown, if any, are typical examples illustrating the operation of the devices. Sony cannot assume responsibility for any problems arising out of the use of these circuits.



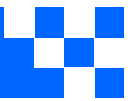

## Camera Module Pinout Definition Reference Chart

OmniVision	Sony	Samsung	On-Semi	Aptina	Himax	GalaxyCore	PixArt	SmartSens	Sensors
Pin Signal		Description							
DGND GND		ground for digital circuit							
AGND		ground for analog circuit							
PCLK DCK		DVP PCLK output							
XCLR PWDN XSHUTDOWN STANDBY		power down active high with internal pull-down resistor							
MCLK XVCLK XCLK INCK		system input clock							
RESET RST		reset active low with internal pull-up resistor							
NC NULL		no connect							
SDA SIO_D SIOD		SCCB data							
SCL SIO_C SIOC		SCCB input clock							
VSYNC XVS FSYNC		DVP VSYNC output							
HREF XHS		DVP HREF output							
DOVDD		power for I/O circuit							
AFVDD		power for VCM circuit							
AVDD		power for analog circuit							
DVDD		power for digital circuit							
STROBE FSTROBE		strobe output							
FSIN		synchronize the VSYNC signal from the other sensor							
SID		SCCB last bit ID input							
ILPWM		mechanical shutter output indicator							
FREQ		frame exposure / mechanical shutter							
GPIO		general purpose inputs							
SLASEL		I2C slave address select							
AFEN		CEN chip enable active high on VCM driver IC							
<b>MIPI Interface</b>									
MDN0 DN0 MD0N DATA_N DMO1N		MIPI 1st data lane negative output							
MDP0 DP0 MD0P DATA_P DMO1P		MIPI 1st data lane positive output							
MDN1 DN1 MD1N DATA2_N DMO2N		MIPI 2nd data lane negative output							
MDP1 DP1 MD1P DATA2_P DMO2P		MIPI 2nd data lane positive output							
MDN2 DN2 MD2N DATA3_N DMO3N		MIPI 3rd data lane negative output							
MDP2 DP2 MD2P DATA3_P DMO3P		MIPI 3rd data lane positive output							
MDN3 DN3 MD3N DATA4_N DMO4N		MIPI 4th data lane negative output							
MDP3 DP3 MD3P DATA4_P DMO4P		MIPI 4th data lane positive output							
MCN CLKN CLK_N DCKN		MIPI clock negative output							
MCP CLKP MCP CLK_P DCKN		MIPI clock positive output							
<b>DVP Parallel Interface</b>									
D0 DO0 Y0		DVP data output port 0							
D1 DO1 Y1		DVP data output port 1							
D2 DO2 Y2		DVP data output port 2							
D3 DO3 Y3		DVP data output port 3							
D4 DO4 Y4		DVP data output port 4							
D5 DO5 Y5		DVP data output port 5							
D6 DO6 Y6		DVP data output port 6							
D7 DO7 Y7		DVP data output port 7							
D8 DO8 Y8		DVP data output port 8							
D9 DO9 Y9		DVP data output port 9							
D10 DO10 Y10		DVP data output port 10							
D11 DO11 Y11		DVP data output port 11							



your BEST camera module partner

## Cameras Applications



[www.KaiLapTech.com](http://www.KaiLapTech.com)



[www.KaiLapTech.com](http://www.KaiLapTech.com)



[www.KaiLapTech.com](http://www.KaiLapTech.com)

[www.KaiLapTech.com](http://www.KaiLapTech.com)



[www.KaiLapTech.com](http://www.KaiLapTech.com)



[www.KaiLapTech.com](http://www.KaiLapTech.com)





## Camera Reliability Test

Reliability Inspection Item		Testing Method	Acceptance Criteria	
Category	Item			
Environmental	Storage Temperature	High 60°C 96 Hours	Temperature Chamber	No Abnormal Situation
		Low -20°C 96 Hours	Temperature Chamber	No Abnormal Situation
	Operation Temperature	High 60°C 24 Hours	Temperature Chamber	No Abnormal Situation
		Low -20°C 24 Hours	Temperature Chamber	No Abnormal Situation
	Humidity	60°C 80% 24 Hours	Temperature Chamber	No Abnormal Situation
	Thermal Shock	High 60°C 0.5 Hours Low -20°C 0.5 Hours Cycling in 24 Hours	Temperature Chamber	No Abnormal Situation
Physical	Drop Test (Free Falling)	Without Package 60cm	10 Times on Wood Floor	Electrically Functional
		With Package 60cm	10 Times on Wood Floor	Electrically Functional
	Vibration Test	50Hz X-Axis 2mm 30min	Vibration Table	Electrically Functional
		50Hz Y-Axis 2mm 30min	Vibration Table	Electrically Functional
		50Hz Z-Axis 2mm 30min	Vibration Table	Electrically Functional
Cable Tensile Strength Test	Loading Weight 4 kg 60 Seconds Cycling in 24 Hours	Tensile Testing Machine	Electrically Functional	
Electrical	ESD Test	Contact Discharge 2 KV	ESD Testing Machine	Electrically Functional
		Air Discharge 4 KV	ESD Testing Machine	Electrically Functional
	Aging Test	On/Off 30 Seconds Cycling in 24 Hours	Power Switch	Electrically Functional
	USB Connector	On/Off 250 Times	Plug and Unplug	Electrically Functional





Inspection Item		Inspection Method	Standard of Inspection	
Category	Item			
Appearance	FPC/ PCB	Color	The Naked Eye	Major Difference is Not Allowed.
		Be Torn/Chopped	The Naked Eye	Copper Crack Exposure is Not Allowed.
		Marking	The Naked Eye	Clear, Recognizable (Within 30cm Distance)
	Holder	Scratches	The Naked Eye	The Inside Crack Exposure is Not Allowed
		Gap	The Naked Eye	Meet the Height Standard
		Screw	The Naked Eye	Make Sure Screws Are Presented (If Any)
		Damage	The Naked Eye	The Inside Crack Exposure is Not Allowed
	Lens	Scratch	The Naked Eye	No Effect On Resolution Standard
		Contamination	The Naked Eye	No Effect On Resolution Standard
		Oil Film	The Naked Eye	No Effect On Resolution Standard
		Cover Tape	The Naked Eye	No Issue On Appearance.
	Function	Image	No Communication	Test Board
Bright Pixel			Black Board	Not Allowed In the Image Center
Dark Pixel			White board	Not Allowed In the Image Center
Blurry			The Naked Eye	Not Allowed
No Image			The Naked Eye	Not Allowed
Vertical Line			The Naked Eye	Not Allowed
Horizontal Line			The Naked Eye	Not Allowed
Light Leakage			The Naked Eye	Not Allowed
Blinking Image			The Naked Eye	Not Allowed
Bruise			Inspection Jig	Not Allowed
Resolution			Chart	Follows Outgoing Inspection Chart Standard
Color			The Naked Eye	No Issue
Noise			The Naked Eye	Not Allowed
Corner Dark			The Naked Eye	Less Than 100px By 100px
Color Resolution			The Naked Eye	No Issue
Dimension	Height	The Naked Eye	Follows Approval Data Sheet	
	Width	The Naked Eye	Follows Approval Data Sheet	
	Length	The Naked Eye	Follows Approval Data Sheet	
	Overall	The Naked Eye	Follows Approval Data Sheet	



## KLT Package Solutions

KLT Camera Module



Complete with Lens Protection Film



Tray with Grid and Space



Place Cameras on the Tray



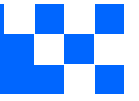

## Camera Modules Package Solution

Full Tray of Cameras



Cover Tray with Lid



Put Tray into Anti-Static Bag



Vacuum the Anti-Static Bag

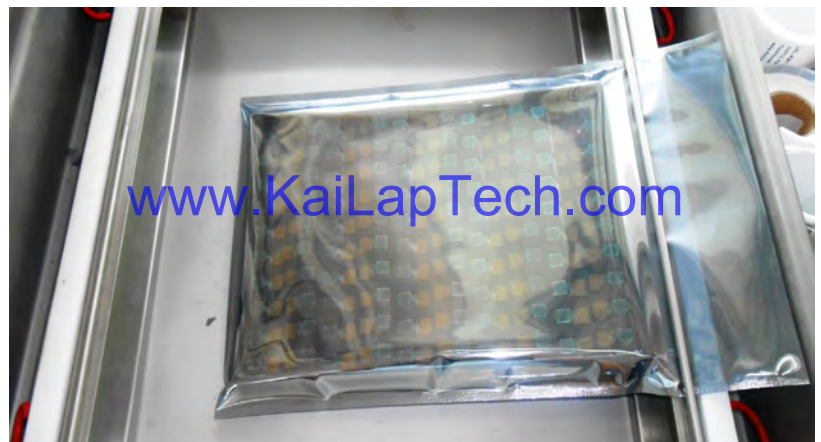



## Camera Modules Package Solution

**Sealed Vacuum Bag with Labels**

- 1. Model and Description 2. Quantity 3. Shipping Date 4. Caution**





# CMOS CAMERA MODULES



*your BEST camera module partner*

## Large Order Package Solution

Place Foam Sheets Between Trays

Foam Sheets are Slightly Larger than Trays



[www.KaiLapTech.com](http://www.KaiLapTech.com)

[www.KaiLapTech.com](http://www.KaiLapTech.com)

Place Foam Sheets and Trays into Box

Foam Sheets are Tightly Fitting Box

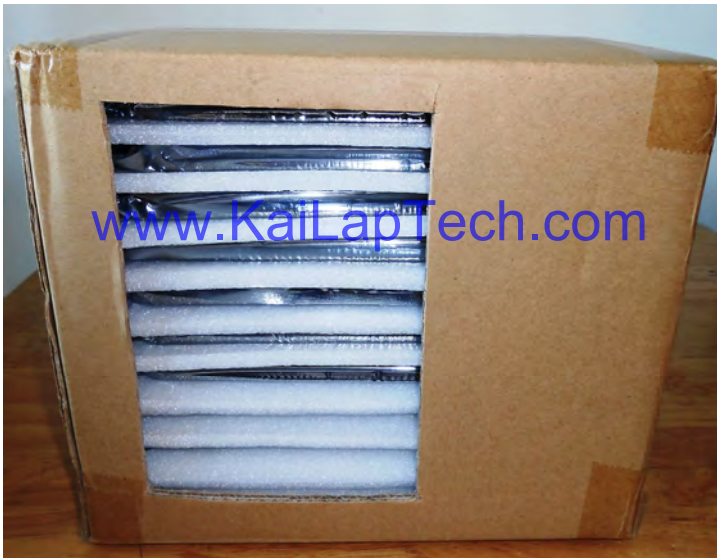

[www.KaiLapTech.com](http://www.KaiLapTech.com) [sales@KaiLapTech.com](mailto:sales@KaiLapTech.com) Tel: (852) 6908 1256 Fax: (852) 3017 6778

All rights reserved @ Kai Lap Technologies Group Ltd. Specifications subject to change without notice.





# CMOS CAMERA MODULES



*your BEST camera module partner*

## Small Order Package Solution

Place Foam Sheets and Trays into Small Box



[www.KaiLapTech.com](http://www.KaiLapTech.com)

Package in Small Box for Shipment

Foam Sheets are Nicely Fitting the Small Box



[www.KaiLapTech.com](http://www.KaiLapTech.com)

Place Small Boxes into Larger Box



[www.KaiLapTech.com](http://www.KaiLapTech.com) [sales@KaiLapTech.com](mailto:sales@KaiLapTech.com) Tel: (852) 6908 1256 Fax: (852) 3017 6778

All rights reserved @ Kai Lap Technologies Group Ltd. Specifications subject to change without notice.

## Carbon Box Package Solution

Seal the Carbon Box

Final Package Labelled Box



### Carbon Box Ready for Shipment

1. Delivery Address and Phone No.
2. Box No. and Ship Date
3. Fragile Caution





## Sample Order Package Solution

Place Sample into Small Anti-Static Bag



Place Connectors into Small Ant-Static Bag



### Sample Labels on the Small Bag

1. Camera Module or Connector Model 2. Shipping Date and Quantity 3. Caution





## Connectors Large Order Package Solution

Connectors in a Wheel



Label Connectors in the Wheel



The Wheel is Perfectly Fitting the Box



Connectors Box Ready for Shipment



## Company Kai Lap Technologies (KLT)

Kai Lap Technologies Group Limited. (KLT) was established in 2009, a next-generation technology driven manufacturer specialized in research, design, and produce of audio and video products. KLT is occupying 20,000 square feet automated plants with 100 employees of annual throughput 30,000,000 units cameras.

KLT provides OEM, ODM design, contract manufacturing, and builds the camera products. You may provide the requirements to us, even with a hand draft, our sales and engineering work together to meet your needs. We consider ourselves your last-term partner in developing practical and innovative solutions.

Our team covers everything from initial concept development to mass produced product. KLT specializes in customized camera design, raw material, electronic engineering, firmware/software development, product testing, and packing design. Our experienced strategic supply systems offer a robust and dependable manufacturing capacity for orders of various sizes.

[www.KaiLapTech.com](http://www.KaiLapTech.com)

[www.KaiLapTech.com](http://www.KaiLapTech.com)



## Limited Warranty

KLT provides the following limited warranty if you purchased the Product(s) directly from KLT company or from KLT's website, [www.KaiLapTech.com](http://www.KaiLapTech.com). Product(s) purchased from other sellers or sources are not covered by this Limited Warranty. KLT guarantees that the Product(s) will be free from defects in materials and workmanship under normal use for a period of one (1) year from the date you receive the product ("Warranty Period").

For all Product(s) that contain or develop material defects in materials or workmanship during the Warranty Period, KLT will, at its sole option, either: (i) repair the Product(s); (ii) replace the Product(s) with a new or refurbished Product(s) (replacement Product(s) being of identical model or functional equivalent); or (iii) provide you a refund of the price you paid for the Product(s).

This Limited Warranty of KLT is solely limited to repair and/or replacement on the terms set forth above. KLT is not reliable or responsible for any subsequent events.





# CMOS CAMERA MODULES



*your BEST camera module partner*

## KLT Strength

### Powerful Factory



[www.KaiLapTech.com](http://www.KaiLapTech.com)

[www.KaiLapTech.com](http://www.KaiLapTech.com)

### Professional Service



[www.KaiLapTech.com](http://www.KaiLapTech.com)

[www.KaiLapTech.com](http://www.KaiLapTech.com)

### Promised Delivery



[www.KaiLapTech.com](http://www.KaiLapTech.com)

[www.KaiLapTech.com](http://www.KaiLapTech.com)



[www.KaiLapTech.com](http://www.KaiLapTech.com)   [sales@KaiLapTech.com](mailto:sales@KaiLapTech.com)   Tel: (852) 6908 1256   Fax: (852) 3017 6778

All rights reserved @ Kai Lap Technologies Group Ltd. Specifications subject to change without notice.